

# Arpeggi8

MIDI Arpeggiator module

User Manual

# Contents

Overview .....	3
Features.....	3
Block Diagram .....	4
Basic Block Diagram of Arpeggi8 .....	4
Connections .....	5
Rear Panel .....	5
Front Panel .....	6
Operation .....	10
Using Arpeggi8 for the first time .....	10
Pattern Variations .....	11
Clock Source .....	12
There are 16 different divide ratios. ....	12
Changing midi channel.....	13
MIDI Implementation.....	14

# Overview

Arpeggi8 is an arpeggiator module designed to be placed in line with any midi module. It enables a vast range of sequenced patterns around single or multiple key combinations.

A simple user interface makes programming simple with all functions available via the front panel interface. All patterns are produced using a custom processor which allows field upgradeable firmware and loading of pattern data.

## Features

- 10 note combination patterns
- 10 swing variations
- Switchable 3 octave range
- Direction – down, up/down and up
- Speed/Tempo – adjustable from 32 BPM to 240BPM, also functions as clock divider for external clock sources.
- Adjustable gate length
- Note hold
- Pattern change modes, allowing internal timing based sequence and note changes or user timings.
- Choice of clock sources, internal, external or midi.
- External CV controls for gate length and tempo.
- Gate outputs from note and pattern start for LFO triggers, etc.

## Block Diagram

The architecture of Arpeggi8 is based around a small microprocessor with a small amount of support hardware to provide analogue interfacing. The following diagram is a basic representation of the internal structure of the processor.

### Basic Block Diagram of Arpeggi8

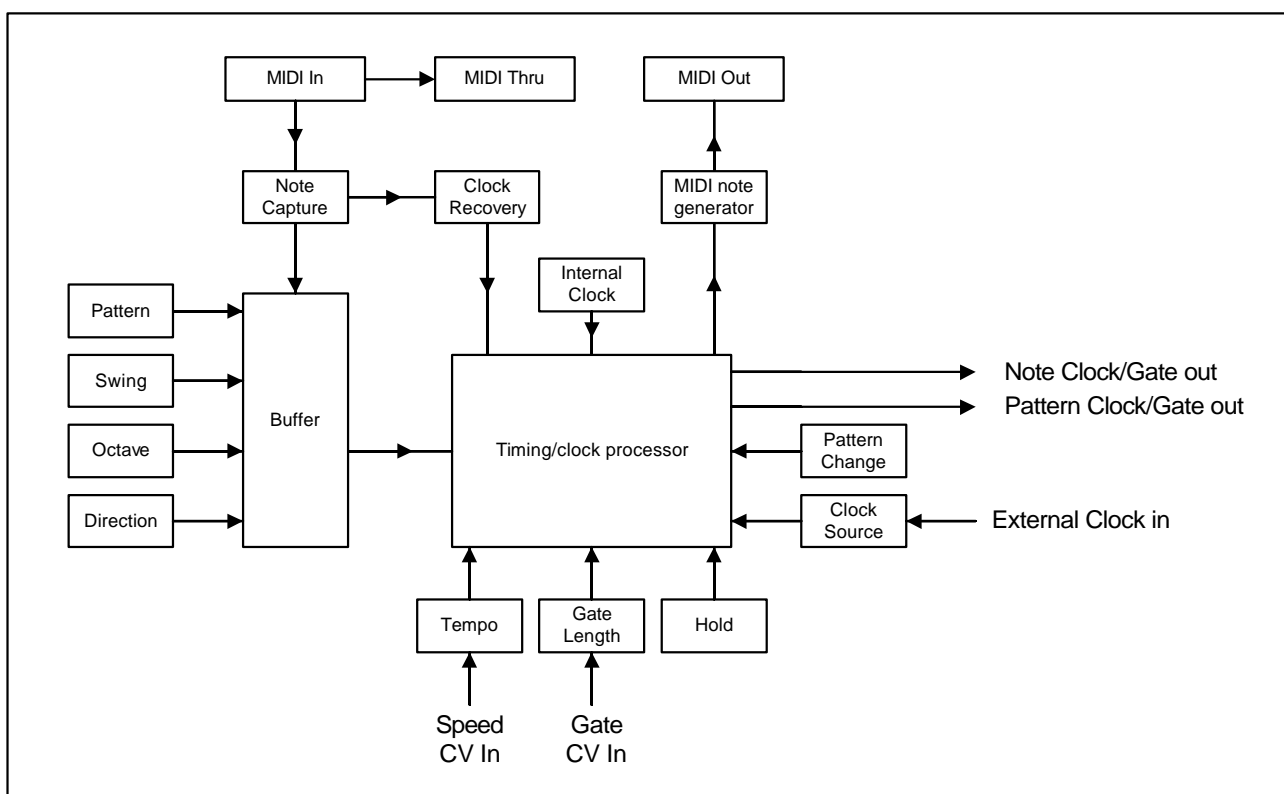

## Connections

How to connect Arpeggi8 into an existing system.

### Rear Panel

Arpeggi8 requires a power supply in the range 6-15V DC @75mA. A plug top style power supply is most suitable although not absolutely necessary.

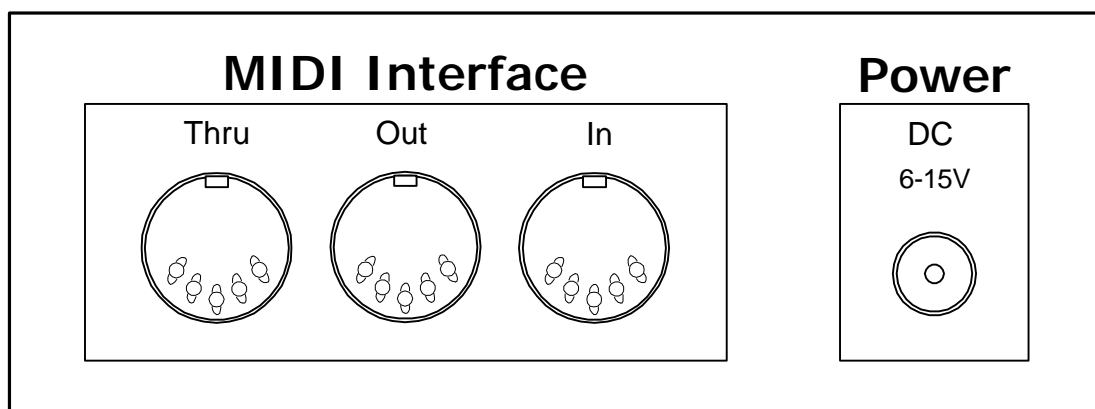

Connect the MIDI In connection of Arpeggi8 to the output of your controller keyboard.

Connect the MIDI Out connection of Arpeggi8 into the MIDI In of your synthesizer or MIDI to CV converter.

If you need to expand your MIDI system without the arpeggio, then use the MIDI thru connection.

# Front Panel

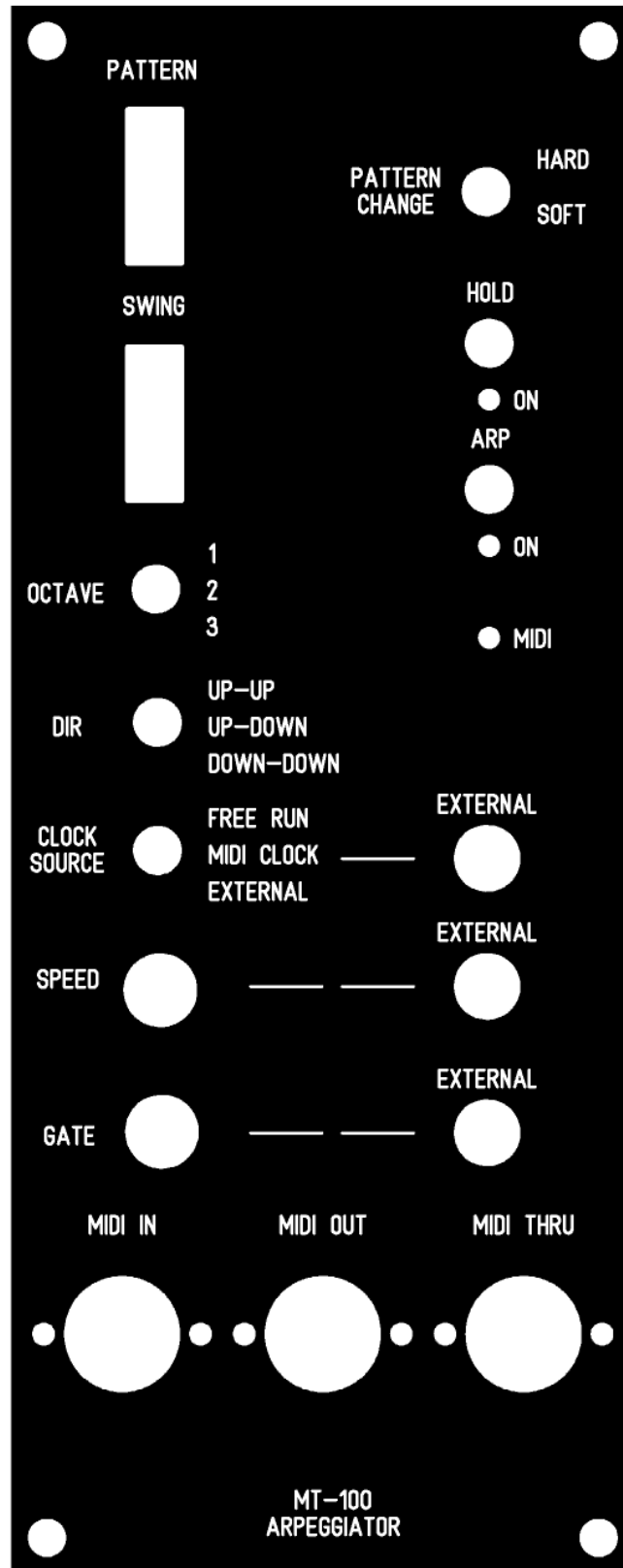

- **Pattern**

Used to select a pattern, Arpeggi8 has 10 different pattern combinations. Pattern 0 is a simple sequence of notes pressed in note order. The note sequence and patterns change as you cycle through the patterns up to 9.

- **Swing**

Swing is used to change the timing of notes used in a pattern. Again there are 10 different swing combinations. Swing 0 uses fixed note lengths and has no rests between notes. The combination of rests and notes lengths changes as swing is increased to 9.

- **Octave**

Octave allows you to play the note pressed and up to 2 octaves above. For example middle C with octave set to 3 will play C4, C5 and C6 in sequence.

- **Direction**

The direction switch allows you to play the notes pressed in 3 modes:

1. Down – this will start with the highest note and play down to the lowest before returning back to the highest note.
2. Up/Down – this will play the lowest note up to the highest note and then back down to the lowest, e.g. G C E C G.
3. Up – will play the highest note and then the next, until reaching the lowest and then returning to the highest.

- **Clock Source**

Once you have chosen your pattern and other parameters, clock source allows three options for timing generation.

1. Arpeggi8's own internal clock
2. MIDI Clock, this uses the clock embedded in the MIDI in stream. This will disable the tempo control and use it for note dividing.
3. External, by using this you can control the timing via an external clock source such as a VCO or LFO.

- **Pattern Change (Quantise)**

Pattern change allows you to make the transition between key or pattern changes follow the pattern order. When set to soft, note and pattern changes will only be changed when the pattern loops back to the start. Hard will change the note and force a restart of the pattern whenever a key is pressed.

- **Arp Switch**

Arp on/off is used to start and stop the arpeggiator. When set to off all notes are automatically passed through. Existing notes are all reset, i.e. the overall effect is all notes off.

If Arp is depressed for more than 2 seconds then MIDI programme mode is entered.

See the chapter [Changing MIDI channel](#) for further information.

- **Arp LED**

Arp LED indicates when the arpeggiator is running. Red indicates the beginning of a pattern. Blue indicates the beats to the bar following the start of the pattern. See chapter xxx for further information.

- **Hold Switch**

Hold allows you to keep the pattern running even when no keys are pressed. The pattern will repeat using the last key/s pressed until further key/s are depressed.

If hold is depressed for more than 2 seconds then ??? mode is entered. See chapter xxx for further information.

- **Hold LED**

This lights when hold mode is selected. See chapter xxx for further information.

- **Speed**

Speed sets the tempo of the chosen pattern, ranging from 60 – 240 BPM.

- **Gate**

Used to set the gate length as a proportion of the overall swing timing and tempo.

- **External Clock**

Allows an external clock source to be used for timing, can be used for sync 24 inputs as used on Roland equipment.

- **External Speed**

This allows the tempo to be varied via an external control voltage (CV).

- **External Gate**

This allows the gate length to be modulated via an external control voltage (CV).

- **Note Gate Out**

Gate output from midi note on, can be used to trigger external filters, etc.

- **Pattern Gate out**

Gate output generated from pattern start, can be used to trigger EG's, etc.

# Operation

The following is a guide to using Arpeggi8 as part of your system.

## Using Arpeggi8 for the first time

- Connect the MIDI out from your keyboard controller to **MIDI IN** of Arpeggi8.
  - Connect the MIDI In of your sound module to **MIDI OUT** of Arpeggi8.
  - Connect a suitable 6-12 VDC plug top power supply.
  - The front panel LED's will cycle during initialization.
  - Arpeggi8 is now ready for use.
- 
- By default Arpeggi8 powers into bypass mode, all notes received are simply passed straight through. Default MIDI channel is channel 1 ( set your keyboard and MIDI sound source to channel 1 ).
  - Pressing notes on the keyboard will loop directly into your sound source and sound should be heard. ( If not then check your connections)
  - The MIDI LED will blink when receiving MIDI data.
  - Set the pattern/swing/octave and direction controls to 0 (default)
  - Set Speed and Gate pots to the 12 o' clock position.
  - Press the Arp button, the LED will light.
  - Press and hold key on the keyboard, the corresponding note will play, but will not play continuously. There will be a repetitive on/off pattern to it.
  - Switch the octave switch from 1 to 2, the original and an additional note 1 octave up will be heard.
  - Adjust the speed pot to vary the tempo.

You have now demonstrated the first principles of Arpeggi8. Try pressing more keys and changing pattern and direction. By now you should see just how many variations are possible.

## Pattern Variations

There are over 300 basic patterns available from a single key press, the number of patterns increase as more keys are pressed.

### Pattern Table

Pattern	Note Sequence	Comment
0	Variation 1	Basic Pattern with no note added.
1	Variation 2	
2	Variation 3	
3	Variation 4	
4	Variation 5	
5	Variation 6	
6	Variation 7	
7	Variation 8	
8	Variation 9	
9	Variation 10	

## Clock Source

Arpeggi8 has three clock modes:

- Internal clock
- Synchronise to incoming MIDI clock data from a drum machine or sequencer.
- External clock

### Internal Clock

Arpeggi8's own internal clock is controlled from the front panel speed control. This is adjustable between 60-240 BPM. In this mode Arpeggi8 also generates MIDI clock for synchronising to other MIDI equipment using Arpeggi8 as a master clock.

### MIDI In clock

When using an external MIDI clock source the speed control, becomes inoperative and is used as a clock divider.

There are 16 different divide ratios.

Settings: 1/1, 1/2, 3/8, 1/4, 1/6, 1/8, 1/12, 1/16, 1/24, 3/32, 1/36, 1/48, 1/72, 1/96

Need more....

## Changing midi channel

To change MID channel on Arpeggi8, press and hold the Arp on/off button for 2 seconds. The Arp LED will flash red to indicate channel programme mode.

The pattern and swing selectors are used to enter MIDI channel.

### Examples

- To set channel 12 as the default MIDI channel, press and hold Arp until the LED begins to flash. Set the pattern to 1 and swing to 2, press and hold Arp to store the channel.
- To set channel 1 as the default MIDI channel, press and hold Arp until the LED begins to flash. Set the pattern to 0 and swing to 1, press and hold Arp to store the channel.



## Features/not sures

**Quantise** probably is the pattern change feature

**Sort** as played, by note, random. (new feature)

	<b>Note Sequence</b>	<b>Comment</b>
0	By Note	By Note Value, Lowest First
1	As Played	By Temporal order
2	Random	Self Explanatory

**Transpose** move a pattern around in hold mode

**Pitchbend** assign to change gate length?

**Modulation** assign to Arp speed

**Ping pong** ping pong output left/right